

S.S.C. HD A module for automatic satellite systems

Installation and user's guide



Register pattern - Design and specifications are subject to change without notice

Warning.

- The reproduction of whole or part of this guide is strictly forbidden without Alden's agreement.
- Alden draws your attention to the risks that may occur if the mounting is not correct. Alden declines all responsibility if the product is not mounted in the correct way and especially if it is installed by a non professional person.
- The retailer is ment to know installation rules and to apply them. He will especially respect the installation location, the cable connection, the glueing and screwing indications.
- By selling and installing an Alden product, the retailer is obliged to inform his customer on how the product works and perhaps how to install the product in some cases. He will also give his customer the user's guide.
- The retailer must inform the customer about security matters.
- The retailer must inform the customer that the product can only be used for the intended matter.
- The retailer must also inform the end user about the current laws applicable in the country where the product is going to be used.
- **Each product with electronic components has to be protected from undervoltage (under 10,5 volts) and overvoltage (over 15 volts).**
- **It is strictly forbidden to open, interfer, repair and/or modify the product without Alden's agreement. The warranty will no longer be applicable if you undertake such an action.**
- **Do not hesitate to call our technical service : 0033 3 88 74 79 40.**

- **If any changes occur concerning the emission frequencies or the power of emission from the satellites, neither the salesperson nor the manufacturer can be held for responsible.**
- **Neither the salesperson nor the manufacturer can be held for responsible if a satellite or a programme come to disappear, if a free-to-air channel becomes scrambled or for any other modification that may affect the emission.**
- **Unpredictable events can not lead to any exchange, refund or compensation from the salesperson nor the manufacturer.**
- **The reception areas of the satellites are given as a guidance.**

Caution.

- ALDEN can not be held responsible in any way, especially in the event of accidents that may occur if the instructions are not respected, whether it be the installation or the use of the product.
- The opening of the devices is strictly forbidden.
- The warranty will be void if these rules are not respected.

Security guidelines.

- Never open/launch the satellite system if it has snowed or by freezing temperatures. Always make sure nothing is blocking the dish such as snow. Remove the blocking items if necessary.
- You **MUST** fold the dish down when driving. To do so follow the closing procedure. Before driving away make sure the dish is in the folding down position.
- When staying parked in the same place for any length of time, remove the fuse from the supply of the receiver.
- **When interfering on the electric circuit, or replacement, or when connection the battery, remove the fuses from the power supply circuit of the satellite unit, search module and receiver. If the vehicle is equipped with a solar panel, also remove the fuse from the regulator.**
- When leaving the vehicle, never leave the dish open.

Requirements:

- **Do not use the existing coaxial cables in the vehicle: the quality of the reception can be altered.**
- **In general, avoid connecting wires together, the quality of the reception signal may weaken. Use a direct wire to connect devices.**
- **It is essential to wire the S.S.C. search module directly from the cell battery with a separate power supply and using a 5amp fuse.**
- **It is essential to wire the Plus after ignition on the S.S.C. directly from the main fuse control panel with a separate power supply and using a 3amp fuse.**
- **Wire the receiver directly from the cell battery with a separate power supply and with an adapted fuse (see further instructions).**

• *By installing this product you accept the previous rules* •

Installation

Warning before installation :

- The system must be in a vertical position in a well ventilated space.
- Do not place the unit near a source of heat or humidity.
- Do not leave the unit directly in the sunlight.
- The ventilation grille must be free. Do not block.
- Do not use existing coaxial circuits. The quality of the picture can be affected. Each link will weaken the signal. Cables of a different type can also change the quality of the picture.
- In all cases :
 - A direct wiring (no links) with a 5A fuse must go from the unit to the battery for the + wire.
 - A direct wiring (no links) must go from the unit to the battery for the - wire.
 - A direct wiring (no links) with a 3A fuse must go from the S.S.C. module to the + after ignition located on the ignition key or on the fuse module.
- When installing with existing wiring, make sure the 3 cases above are respected.
- Always use the provided cables
- The warranty will no longer be applicable if these instructions are not followed.

1. Cut out the drilling layout page 12.
2. Place the drilling layout at the chosen spot and respect the orientation of the module.
3. Place the screws at each mark and leave about 3mm of the screws out of the wall.
4. Put the module in place.
5. Undergo the wiring following the layout page 4 and 5.

General wiring diagram

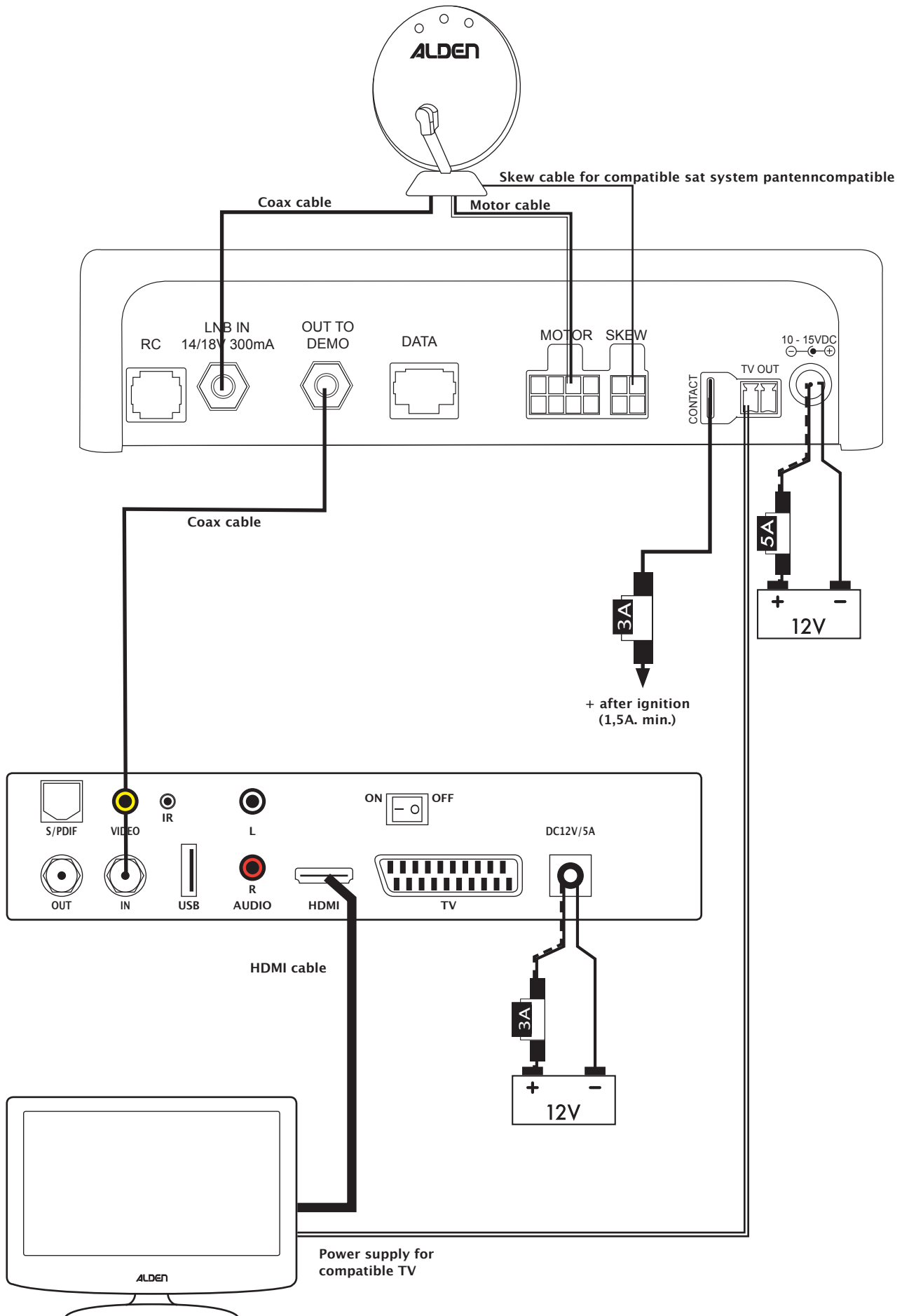

S.S.C. wiring diagram

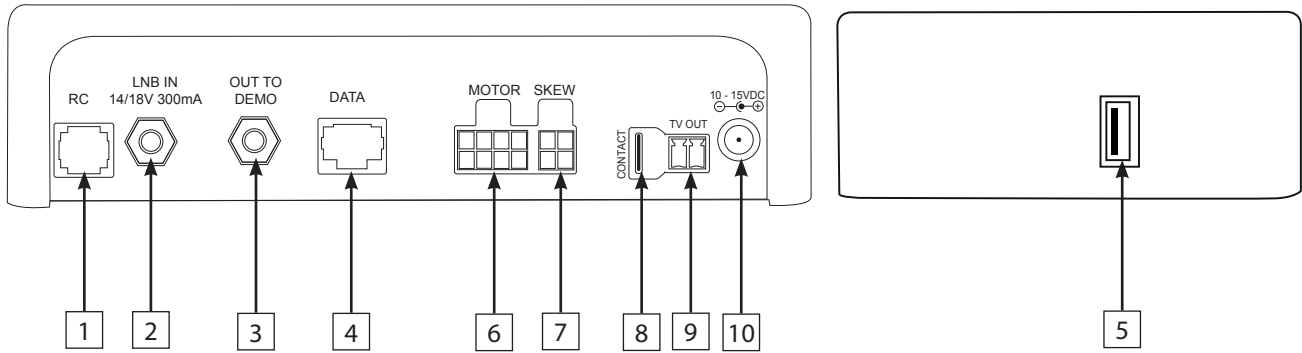

N° : description	Type of connection	Input and output description
1 : RC		Optionnel: Interface utilisateur déportée.
2 : LNB in	F Type coaxial	Connection with the sat-unit's LNB.
3 : Out to demo	F Type coaxial	Connection used to connect the SSC module to the receiver or satellite TV.
4 : Data		For Alden's use only
5 : USB	USB	Used to update the data.
6: MOTOR	Power	Used for the motorisation of the sat-unit.
7: SKEW	Skew	Used for the motorisation of the LNB (if sat-u,it is compatible)
8: CONTACT	Spade connector	Folding security system connected to the car ignition.
9 : TV OUT	TV output	Used to power up a 12V/3A max. TV
10 : 10-15V DC	Jack DC	12V SSC Power supply

Warning - Reminder :

- The system must be in a vertical position in a well ventilated space.
- Do not place the unit near a source of heat or humidity.
- Do not leave the unit directly in the sunlight.
- The ventilation grille must be free. Do not block.
- Do not use existing coaxial circuits. The quality of the picture can be affected. Each link will weaken the signal. Cables of a different type can also change the quality of the picture.
- In all cases :
 - A direct wiring (no links) with a 5A fuse must go from the unit to the battery for the + wire.
 - A direct wiring (no links) must go from the unit to the battery for the - wire.
 - A direct wiring (no links) with a 3A fuse must go from the S.S.C. module to the + after ignition located on the ignition key or on the fuse module.
- When installing with existing wiring, make sure the 3 cases above are respected.
- Always use the provided cables
- The warranty will no longer be applicable if these instructions are not followed.

Working principle

The S.S.C. HD Module (Satellite Search Control) is a module designed to search for satellites such as Astra 19, Astra 3, Astra 2 (North & South), Hotbird, AB 3, Thor, Sirius, etc.. The module can be used with all Alden's satellite systems and connected to any digital receiver allowing the reception of the broadcasted programmes on the chosen satellite. The S.S.C. module is specially adapted for a use in a leisure vehicle.

Description

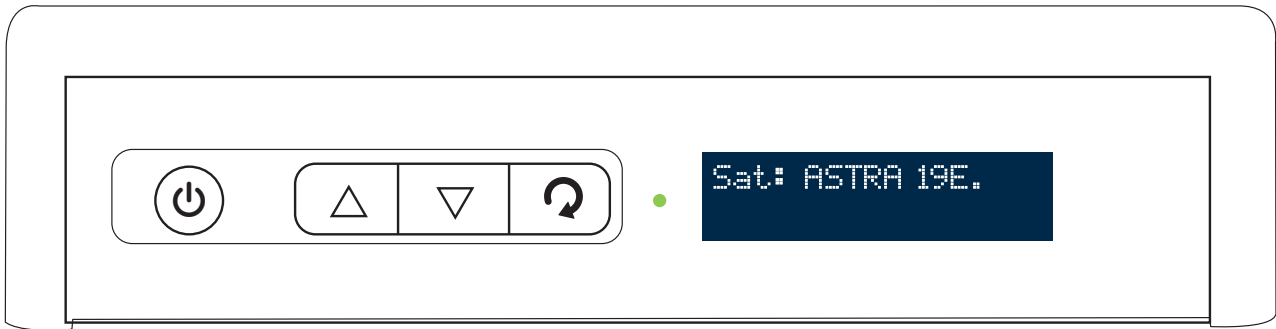

<i>Designation</i>	<i>Function</i>
⏻	Switch the module on/off.
▲	Select the satellite/navigate in the menu.
▼	Close the dish/navigate in the menu.
🔄	Access to the setting menu. SKEW option management.
Green Led •	On: The S.S.C. is in stand by mode Off: The S.S.C. is off (Power intake = 0 Amps)

How to use the S.S.C.

1. Turn the S.S.C. Module on by pressing \odot .
2. By using \blacktriangle , choose the satellite.
Keep pressing this button to switch from one satellite to another.
Each time you change satellites you will hear a beep tone.
The satellites are programmed in the following order:

ASTRA 19 • ASTRA 23 • HOTBIRD 13 • AB3 • Astra 4.8 • ASTRA 28 ...

<i>Satellite*</i>	<i>Broadcast</i>
ASTRA 19° E	Various channels, various languages and CanalSat, TNTSAT
ASTRA 23° E	Belgian and dutch channels
HOTBIRD 13° E	Various channels, various languages
EUTELSAT 5° W	French channels (Fransat/Bis TV)
ASTRA 4.8A	Various channels, various languages
ASTRA 28° E /N	English channels (BBC, SkyNews...)
ASTRA 28° E /S	English channels (BBC, SkyNews...)

3. Once \blacktriangle released, the chosen satellite LED will flash for a few seconds, then will stay on display.
The message «Search...» will appear : meaning that the satellite system is searching the chosen satellite.
Once the satellite found, the message «Pointing OK!» will appear.
4. Power on the receiver and TV, choose a programme on the corresponding satellite.

Warning : Every time you use the S.S.C, the last chosen satellite will automatically be selected.

* The satellite may vary depending on the software version.

How to change satellites when using the system

1. By using \blacktriangle , select the chosen satellite.
2. Once \blacktriangle released, the chosen satellite LED will flash a few seconds, then will stay on display.
The message «Search...» will appear : meaning that the satellite system is searching the chosen satellite.
Once the satellite found, the message «Pointing OK!» will appear.

How to change the skew area

1. This chapter is useful if your antenna is fitted with the skew option.
2. Once the satellite has been chosen (nb. previous chapter), when the message «Skew Area»: appears, press the \odot button to select your location thanks to the map (see maps next pages).

Closing principle

1. Press the \blacktriangledown button on the S.S.C. module, the message «Close» will appear. The message will disappear once the satellite system will be fully closed.
2. Switch the receiver, S.S.C module and television off.

Warning : The warranty will be void if you do not close the dish





Map of the zones of skew orientation



Zone 3

Zone 4

Setting Menu

To reach the SETUP menu, fold the antenna and then press the  button. Select one of the sub-menus using the   keys and confirm by pressing the  key.

1. TRANSP. MOD : Search data settings.

This menu enables to select and set the data used for the search of the satellite.

Caution: if not used correctly you may cause the module to dysfunction. Do not use without Alden's or your dealer's advice.

2. EXT. BOOT : when used, this function enables you to launch an automatic search on the chosen satellite when using the module connected to the OUT TO DEMO output on your S.S.C.

Caution: prior to this, the S.S.C. has to be in stand by modus (green LED on) for the function to be accepted.



3. ANT STATUS : When set on «NO», when switching the system off, the satellite system will remain open, orientated towards the satellite. On the opposite, when set on «YES», the satellite system will close itself automatically when you switch the installation off.

4. POWER OPTION : When this menu is set on «YES», it enables to put the S.S.C. in stand by mode when the externale receiver connected to the OUT TO DEMO input is not used. When this menu is set on «NO», the S.S.C. switch itself off (power consumption = 0amps) when the externale receiver connected to the OUT TO DEMO input is not used.

5. LANGUAGE : Select your language to visualize the different menus.

6. VERSION : Provides information on the software version and product.

7. MEC. ANTENNA : Indicates the kind of satellite system which is connected to the S.S.C.



This menu also enables you to change the kind of automatic satellite system (only Alden brand). Using   choose the corresponding satellite system. Press  to confirm your choice.

8. DiseqC MENU : When this function is active, a number will be assigned to a satellite (DiseqC standard) and this information will also be available in the receiver/television connected to the OUT TO DEMO on the S.S.C.. This function enables you to search automatically for a satellite when changing satellites on you receiver/television.

Example: if the receiver is programmed as the following :

Astra 19 -> DiseqC 1.1 : 1
Hotbird 13 -> DiseqC 1.1 : 2



Match a number to a satellite by using  
Press  to confirm each of the 8 satellites.

Caution: only one number per satellite, one satellite can not have several numbers.

NB: if your receiver is only compatible DiseqC 1.0, refer to the following details:

Letter	Corresponding number
A	1
B	2
C	3
D	4

Caution: the receiver or television must be compatible with a DiseqC 1.0 or 1.1 to enable you to use this function on the S.S.C..

9. ES/Nb N° Menu : Indicates the level of reception of the satellite system. The higher the level, the better the quality of the reception.

Caution: The value is given as an indication.

10. Upgrade : This menu allows you to update the SSC HD using a USB key.

11. Advanced Setting-> display orientation: Activating this function will rotate the display of the screen giving you the possibility to fix the module upside-down in the storage cabinet

12. Exit: close the menu

Preprogrammed mechanics

Mechanical name	
ORB2CC	Orbiter with 2 red arms (4 screws fixing the engine's cover)
ORB2EE	Orbiter with 2 red arms (4 screws fixing the engine's cover)
ORB2EC	Orbiter with 2 red arms (4 screws fixing the engine's cover)
ORB3EC	Orbiter with 2 red arms (3 screws fixing the engine's cover)
OL2_L	Onelight with 2 red pieces and LNB fork
OL2R	Onelight with 2 red pieces and LNB fork
SKYEE	Skymatic
SKYEC	Skymatic
AS4	AS4 antenna (60 and 80 cm) See sticker on the base of the antenna.
AS4_3	AS3 antenna (60 and 80 cm) See sticker on the base of the antenna.
AS2	AS2 antenna (60 and 80 cm) See sticker on the base of the antenna.
PLANAR_L	Planar
ORBITER +	Orbiter see sticker on the base of the antenna.
AS 2.1	See sticker on the base of the antenna.
OL1_L	Onelight with 1 red piece and LNB fork
OL1_R	Onelight with 1 red piece and LNB fork
OR1CC	Onesat / Orbiter with only one red piece.
OR1EE/SS	Onesat / Orbiter with only one red piece.
PLANAR +	Not sold.
OL3	Onelight 3 /EVO.
SAT-LT	Antenne VANSAT Portable. See sticker on the base of the antenna.
SMALLSAT	Smallsat
AS4_85 AUS	See sticker on the base of the antenna.
ORB+_AUS	See sticker on the base of the antenna.
EURO85	Eurobird.
SATNET75@	SatNet75.
ORB2@ 80 PL	Orbiter Internet 80.
OR1SS1/100	Orbiter with only one red piece.
MONDO@	
VANSAT_CC	Vansat. Sold until the end of 2013.
PLANAR_R	Not sold.
MONDO	
ORB3CC	Orbiter with 2 red arms (3 screws fixing the engine's cover).
SKY AUS	See sticker on the base of the antenna.

What to do if the system breaks down

Problem	Solution
The message «LNB Short-cut!» is displayed	There is a short circuit on the coax cable between the LNB on the satellite system and the LNB IN on the S.S.C. Check the corresponding cable.
The message «NB Error! » is displayed	The coax cables connected to the LNB IN and OUT TO DEMO are inverted.
The message «LNB Disconnected» is displayed	There is no connection between the sat unit LNB and the LNB IN on the S.S.C. Check the corresponding cable.
The message «Antenna is stuck» is displayed	The S.S.C has detected a steering problem on the automatic sat unit. Check the motor cable between the S.S.C. and the automatic sat unit.
The message «Low Battery!» is displayed	The voltage on the battery or on the power supply is too low. Charge the battery or change the power supply.
The message «-> Secu contact» is displayed	The S.S.C. has detected the presence of the security contact. The automatic sat unit will not be able to open. Stop the vehicle's engine to use the S.S.C..
The satellite system does no longer find the satellite	Make sure there is no obstacle in front of the satellite unit (building, tree...). When the transmitter changes the frequencies, the positioning will not be done properly. Contact a technician or connect to our website www.alden.fr .

Technical features

Frequencybord : KU

Frequency : 10,7 à 12,75 GHz

Polarization : Horizontal and Vertical

Power supply : 12 V DC

Power : 13 W maximum

Operating temperature : +15°C à +50°C

Humidity rate : 85 % maximum

Dimensions : l = 167 mm

h = 110 mm

p = 45 mm

Weight : 0,30 kg

Stand by consumption : 0,03 A

Warning before installation :

- The system must be in a vertical position in a well ventilated space.
- Do not place the unit near a source of heat or humidity.
- Do not leave the unit directly in the sunlight.
- The ventilation grille must be free. Do not block.
- Do not use existing coaxial circuits. The quality of the picture can be affected. Each link will weaken the signal. Cables of a different type can also change the quality of the picture.
- In all cases :
 - A direct wiring (no links) with a 5A fuse must go from the unit to the battery for the + wire.
 - A direct wiring (no links) must go from the unit to the battery for the - wire.
 - A direct wiring (no links) with a 5A fuse must go from the S.S.C. module to the + after ignition located on the ignition key or on the fuse module.
- When installing with existing wiring, make sure the 3 cases above are respected.
- Always use the provided cables
- The warranty will no longer be applicable if these instructions are not followed.

Drilling layout

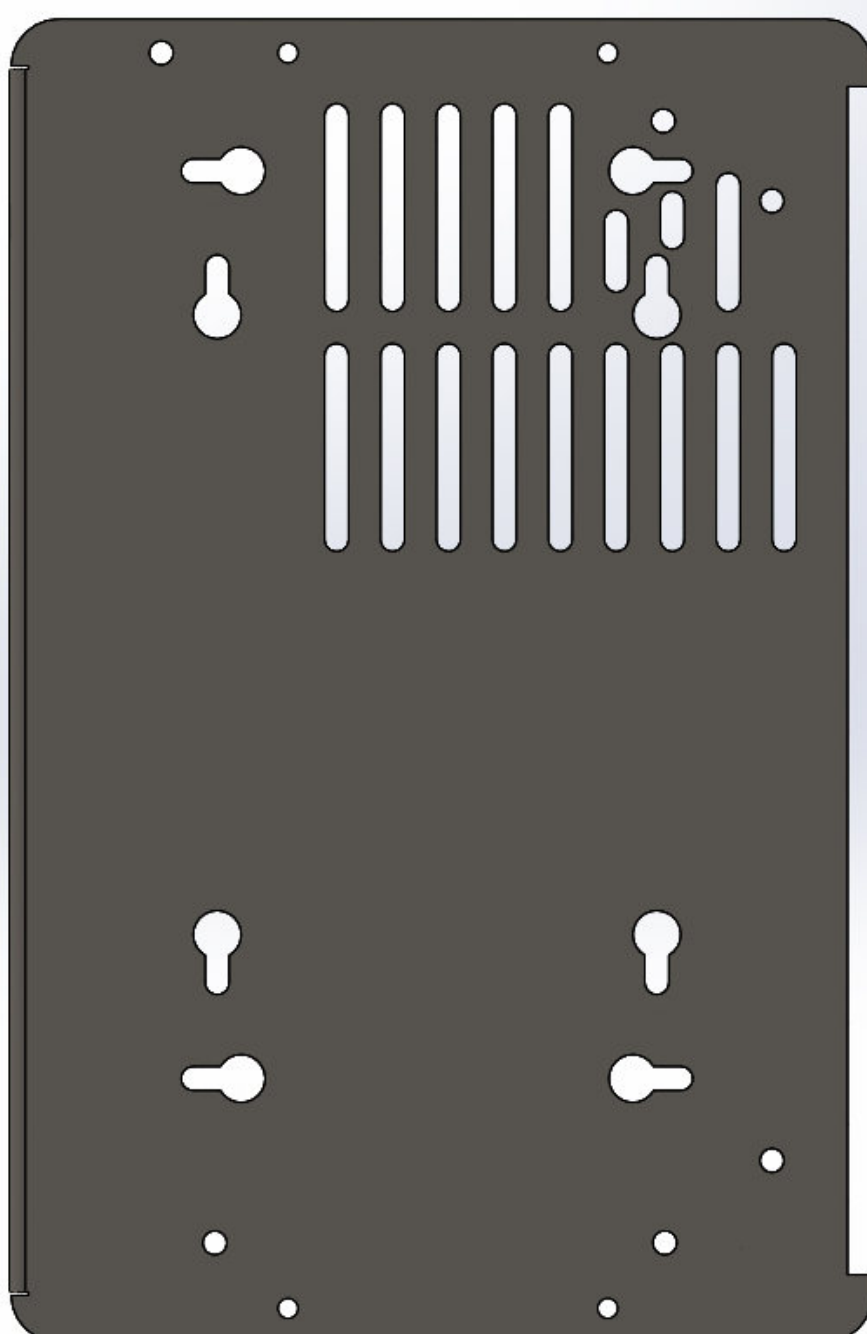



WEEE Directive (European Union and EEA only).

This symbol indicates that this product is not to be disposed of with your household waste, according to the WEEE Directive (2002/96/EC) and your national law. This product should be handed over to a designated collection point, E.G., on an authorized one-for-one basis when you buy a new similar product, or to an authorized collection site that recycles waste electrical and electronic equipment (EEE). Improper handling of this type of waste can have a negative impact on the environment and human health due to potentially hazardous substances that are generally associated with EEE. By respecting this directive, you will contribute to the effective usage of natural resources. For more information about where you can dispose of your equipment for recycling, please contact your local city office, or other authority, approved WEEE scheme or your household waste disposal service. (EEA : Norway, Iceland and Liechtenstein)