

# VOTRONIC

## Installation and Operating Manual

**StandBy-Charger Pro** Input 12...15 V max. 12 A, Output 12,5...14,5 V max. 8 A

**No. 3063**



Figure 1: front view of StandBy-Charger Pro

Device for recharging and trickle charge a battery from another battery.



Please read this operating and installation manual thoroughly prior to connection and start-up.

The VOTRONIC StandBy-Charger serves for recharging and trickle charge of the starter battery in vehicles with two battery circuits. A possible connection can be made between the supply or body battery and the starter battery. Only the operation with two same nominal battery voltages 12V / 12V is permitted. Mixed operation 12V and 24V is not allowed.



Only the operation with two equal rated battery voltages 12 V/12 V is permissible, mixed Operation 12 V and 24 V is not allowed.

### Device mounting

The StandBy-Charger Pro should be installed as close as possible to the battery to be charged and protected from moisture. The StandBy-Charger Pro can be mounted at the external attachment points of the casing as shown in figure 2 (specifications in mm).

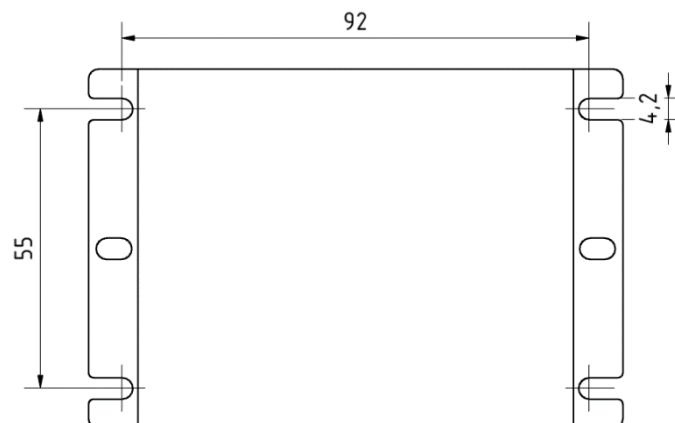

Figure 2: dimensions of the attachment points of the casing

## Connection

- The device is connected between the input and output battery. The plus (+) and minus (-) connections of the batteries must be connected to the corresponding terminal on the input and output side. Note the polarity! The battery on the output side can be connected after the potentiometers have been adjusted.

Terminal	Description
IN+	Positive terminal (+) of the input battery
IN-	Negative terminal (-) of the input battery
OUT+	Positive terminal (+) of the output battery
OUT-	Negative terminal (-) of the output battery
EN	Non-inverted enable signal for activating the StandBy-Charger Pro
DIS	Inverted enable signal (e.g. D+ signal of the alternator) for disabling the StandBy-Charger Pro (optional)

- The connection cables should have a cable cross-section of 1 mm<sup>2</sup> to 4 mm<sup>2</sup> (see Table 1) and must be protected against overload (cable fire) in accordance with the cable cross-section, e.g. fuse 10 A.
- To activate the StandBy-Charger Pro permanently, a jumper can be connected from *IN+* to *EN*. Alternatively a switchable 12 V control signal can be applied to the *EN* terminal for turning the StandBy-Charger Pro on and off.
- If the StandBy-Charger Pro should be deactivated while the output battery is being charged by the alternator, the D+ signal of the alternator can optionally be connected to the *DIS* terminal.

For full charging capacity, dimension **cable cross-sections and lengths** according to Table 1. The described length refers to the total length of the supply and return conductor. For a **two-wire cable the half of the specified cable length** is recommended.

Table 1: Cable cross-sections and lengths

Cable cross-sections	12 V input battery		12 V output battery	
	Sum of cable lengths „IN+ and IN-“	Cable protection fuse	Sum of cable lengths „OUT+ and OUT-“	Cable protection fuse
0,75 mm <sup>2</sup>	-	-	up to 2,1 m	10 A
1 mm <sup>2</sup>	up to 1,8 m	15 A	up to 2,8 m	10 A
1,5 mm <sup>2</sup>	up to 2,7 m	15 A	up to 4,2 m	10 A
2,5 mm <sup>2</sup>	up to 4,6 m	15 A	up to 7 m	10 A
4 mm <sup>2</sup>	up to 7,4 m	15 A	up to 11,2 m	10 A

### Notes:

- To charge the output battery to the adjusted voltage level as much as possible, place StandBy-Charger Pro as close as possible to the battery to be charged.
- Mixing up "IN+" and "IN-" or "OUT+" and "OUT-" (reverse polarity at the input or output) can lead to the destruction of the device.
- The device is not designed for operation with 24 V batteries. Incorrect connection can lead to the destruction of the device.

## Commissioning

After connecting the input battery, set the desired shutdown threshold on the input side via the  $U_{INLO}$  potentiometer. This prevents the input battery from discharging too deeply. If the input voltage is sufficient and the  $EN$  signal is connected (device is active), the output voltage can now be set via the potentiometer  $U_{OUT}$  with using a connected voltmeter at the output terminals. Afterwards, connect the output battery to the device. If the StandBy-Charger Pro is activated via the terminal  $EN$  and is not switched off by the terminal  $DIS$ , the charging of the output battery starts automatically if required. The StandBy-Charger Pro is now ready for use.

If the battery on the input side is charged via e.g. a mains charger, a solar system or similar, the output battery is charged with max. 8 A to the previously set voltage.

Different battery types require different charging voltages. The corresponding charging voltage can be obtained from the battery manufacturer's data sheet.

The following minimum and maximum values are possible via the potentiometers  $U_{INLO}$  and  $U_{OUT}$ :

Potentiometer	Limit stop	Description
$U_{INLO}$	left	$U_{INLO} = 12 \text{ V}$
	right	$U_{INLO} = 14 \text{ V}$
$U_{OUT}$	left	$U_{OUT} = 12,3 \pm 0,2 \text{ V}$
	right	$U_{OUT} = 14,5 \text{ V}$

**Note:**

- If the set output voltage is below the battery voltage connected to the output, the StandBy-Charger Pro shuts down.

Device function depending on the control inputs  $EN$  and  $DIS$ :

EN	DIS	Device function
10 - 15 V	0 V	active
	10 - 15 V	inactive
0 V	0 - 15 V	



For a correct setting of the charging voltage, the output voltage must be determined using a voltmeter in no-load operation, i.e. without connecting the  $OUT+$  and  $OUT-$  terminals.

1. Connect the battery and the enable signal "EN" on the input side and set the shutdown threshold on the input side via the potentiometer  $U_{INLO}$

Note: For commissioning, this must be  $\geq$  the input battery voltage

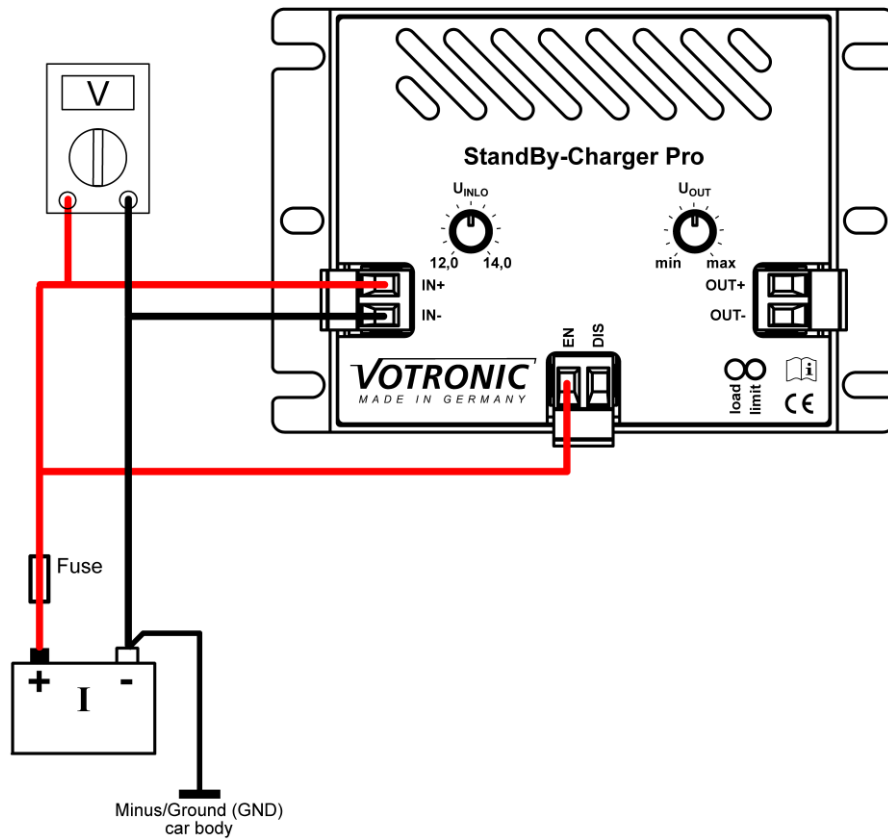

2. Set the end-of-charge voltage via potentiometer  $U_{OUT}$

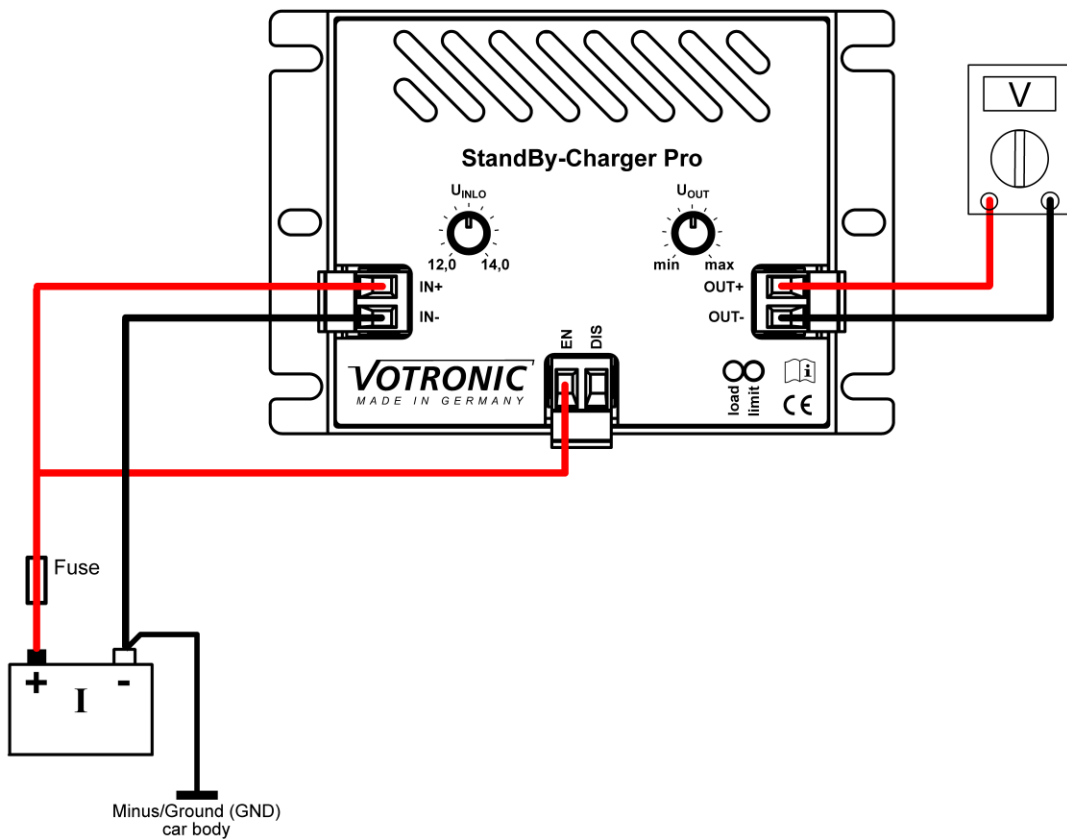

### 3. Connect the battery on the output side

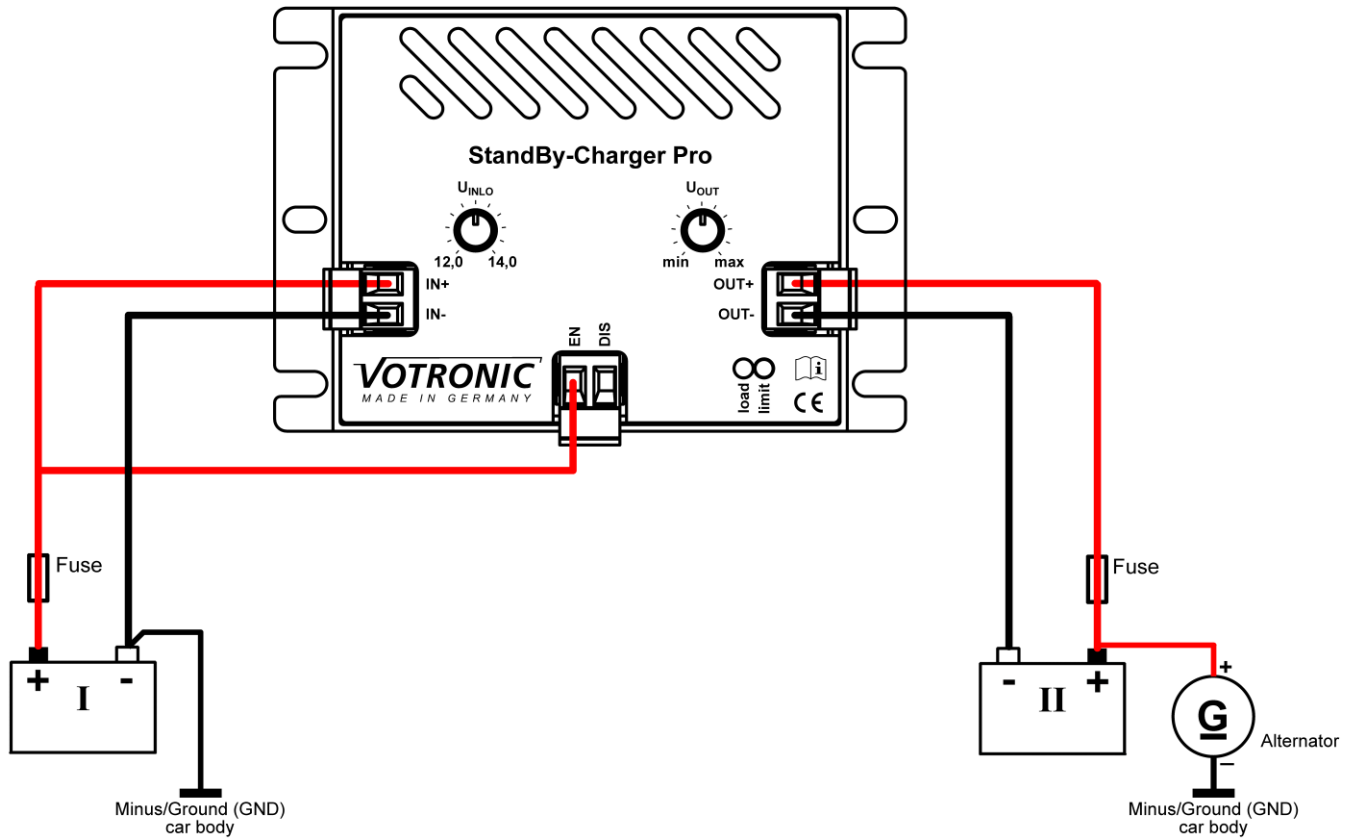

### Operation indicators

**Note:**

For a correct operation indicator it is necessary to connect a battery to the *OUT+* and *OUT-* terminals.

LED 1 (green)	LED 2 (yellow)	State
Off	Off	Standby <sup>1</sup> / input voltage too low / set output voltage is lower than the voltage of the output-side connected battery
On	Off	Charges actively with set output voltage
On	On	Charges actively with set output voltage and maximum possible charging current <sup>2</sup>

<sup>1</sup> *EN* signal is not active or *DIS* signal is active

<sup>2</sup> If no battery is connected to the output terminals, both LEDs may light up permanently without the StandBy Charger Pro being active

## Technical Data

### Input „IN“

Nominal operating voltage DC	12 V
Input voltage range	12...15 V
Input shutdown threshold range	12...14 V
Current consumption in standby	<1 mA
Max. current consumption	12 A
Terminal cable cross-sections (flexible without ferrule)	1...4 mm <sup>2</sup>

### Output „OUT“

Nominal operating voltage DC	12 V
Output voltage range	12,5...14,5 V
Max. output current	8 A
Terminal cable cross-sections (flexible without ferrule)	0,75...4 mm <sup>2</sup>

### Control signals „EN“ and „DIS“

Nominal voltage	6...15 V
Terminal cable cross-sections (flexible without ferrule)	0,25...4 mm <sup>2</sup>

### General information

Battery types	lead batteries (acid, AGM, Gel) or lithium-LiFePO <sub>4</sub> (see security guidelines)
Working temperature range	-20...+45° C
Safety shutdown in case of overheating	available
Dimensions (LxWxH)	71 mm x 105 mm x 25 mm
Weight	ca. 92 g
Fitting position of unit	any
Protection class	IP2X
Ambient conditions, humidity of air	max. 95 % RH, no condensation
Screw tightening torque	0,5 Nm
Stripping length cable	6 mm
Efficiency $\eta$ (@ 12,5 V IN/14,4 V OUT)	95 %

**Notes:**



### Safety guidelines and intended use:

The charger has been built in accordance with the applicable safety guidelines.

#### Only use for following application:

1. For charging lead-gel, lead-AGM, lead-acid or lithium-LiFePO<sub>4</sub> (with integrated BMS, balancing, protective circuit and approval!) batteries of the specified nominal voltage in fixed or mobile installed systems.
2. With the specified cable cross-sections at the device terminals.
3. With fuses of the specified rating near the batteries to protect the wiring between the batteries and the device.
4. With technically impeccable condition.

**The device must never be used at locations where there is a risk of gas or dust explosion!**

- Open-air operation of the unit is not allowed.
- Lay cables in such a way that they cannot be damaged; make sure that they are well mounted.
- Never lay 12 V (24 V) cables and 230 V mains supply cables into the same cable conduit (empty conduit).
- Regularly inspect live cables or lines for isolation faults, fractures and bad connected or overloaded terminals and rectify defects if necessary.
- The unit is to be disconnected from any connection prior to execution of electrically welding or work on the electric system.
- If it is not clear to the non-commercial user from the descriptions provided which characteristic values apply to a unit or which regulations must be observed, the information of a specialist must be obtained.
- Compliance with manufacturing and safety regulations of all kinds is the responsibility of the user / purchaser.
- Keep children away from batteries and connections.
- Observe the safety instructions of the battery manufacturer and ventilate the battery room.
- Non-observance can lead to personal injury and material damage.
- The warranty period is 36 months from the date of purchase (on presentation of the receipt or invoice).
- The warranty becomes void if the device is not used for the intended purpose, if it is operated outside the technical specifications, if it is operated improperly or if it is tampered in any way. No liability is accepted for any resulting damage. The exclusion of liability also extends to any service work carried out by third parties and not commissioned by us in writing. Exclusively VOTRONIC Elektronik-Systeme GmbH provides services.



### Declaration of Conformity:

In accordance with the provisions of Directives 2014/35/EU, 2014/30/EU, 2009/19/EC, this product complies with the following standards or normative documents:  
EN55014-1; EN61000-6-1; EN61000-4-2; EN61000-4-3; EN61000-4-4;  
EN62368-1; EN50498.



The product must not be disposed of in the household waste.



The product is RoHS compliant. It complies with the directive 2015/863/EU for Reduction of Hazardous Substances in electrical and electronic equipment.

**Quality Management  
System**

**DIN EN ISO 9001**



### Recycling:

At the end of its useful life, you can send us this device for professional disposal:  
You can find more information about this on our website at [www.votronic.de/recycling](http://www.votronic.de/recycling)

### Delivery Scope:

- 1 StandBy-Charger Pro
- 1 Installation and Operating Manual

Subject to misprints, errors and technical modification without notice.

All rights reserved. This material may not be published, broadcast, rewritten or redistributed in whole or part without the express written consent of the manufacturer. Copyright © VOTRONIC 08/2023

Made in Germany by VOTRONIC Elektronik-Systeme GmbH, Johann-Friedrich-Diehm-Str. 2, 36341 Lauterbach/GERMANY

Phone: +49 (0)6641/91173-0 Fax: +49 (0)6641/91173-10 E-mail: [info@votronic.de](mailto:info@votronic.de) Internet: [www.votronic.de](http://www.votronic.de)