

Perfektium LiFePO4 Battery 12.8V 100Ah

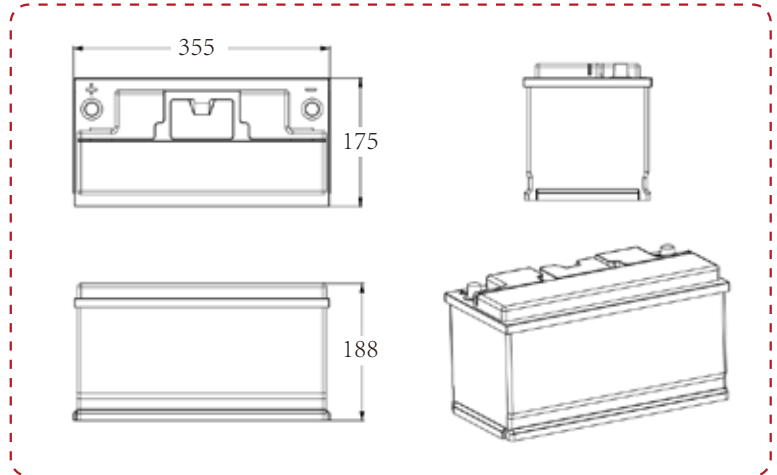

Items

Normal capacity	100Ah
Nominal energy	1280Wh
Nominal voltage	12.8V
Cell	Prismatic Module
Charge Characteristic	CCCV / IU
Cycle Life	>6000@80%D.o.D
Internal resistance	≤15 mΩ @ 50% SOC
Normal charge voltage	14.6±0.2V
Float charge voltage (For standby use)	13.8±0.8V
Allowed MAX charge current	50A
Recommended charge current	30A
Allowed MAX discharge current	150A
Peak Discharge Cut-Off (3.0s)	450A (200 ~ 500 ms)

Items

End of discharge voltage	10V (2000 ms)	
Monitoring	Bluetooth 4.0 With Smartphone APP	
Dimension (L×W×H) in MM	355×175×188	
Weight (No accessories)	12±0.5kg	
Operation temperature	Charge	-35 ~ 50°C
	Discharge	-35 ~ 75°C
Self-discharge rate	Recover capacity	≤3%/Month; ≤15%/Year
	Residual capacity	≤1.5%/Month; ≤8%/Year
Storage environment	≤1month	-35 ~ 60°C 5 ~ 75%RH
	≥3month	-10 ~ 45°C 5 ~ 75%RH
	Recommend environment	15 ~ 35°C 5 ~ 75%RH
Bluetooth APP	Perfektium	
Series & Parallel	4 series and 4 parallel	

Distributed by



RoadPro Ltd,
3 Egerton Close,
Daventry,
Northants, NN11 8PE

E-mail: sales@roadpro.co.uk
Website: www@roadpro.co.uk

