



## AMT12-2 Installation Instructions

The AMT12-2 is a 2A Trickle Charger / Battery Maintainer for maintaining a Vehicle Battery at full charge when a Solar or Mains Charger is used to charge a Leisure / Auxiliary Battery. The Trickle Charger charges the Vehicle Battery if the Leisure Battery is at more than the Leisure Battery threshold & the Vehicle Battery is less than the Vehicle Battery threshold. The unit charges for 3s & then switches off for 15s. The current is limited to a maximum of 3A, It also charges if the Leisure Battery is 0.3V(1.0V Lithium) higher than the Vehicle Battery & the Vehicle Battery is less than 12.1V. This is to pool charge & optimise the retention of charge across both Batteries to maintain Battery life. There is no charging if the Vehicle Battery is flat (ie less than 11.5V).

**The unit is shipped configured for a Smart Alternator Vehicle & Regenerative Braking ie SETTING 4** in the table below but it is easily configured by the user with higher settings for older Vehicles. The customer can configure for use with Lithium Batteries. The unit is also configured to automatically detect Battery Voltage & so will work with 24V Batteries.

**Mechanical:** This unit should be mounted subject to the drawing below.

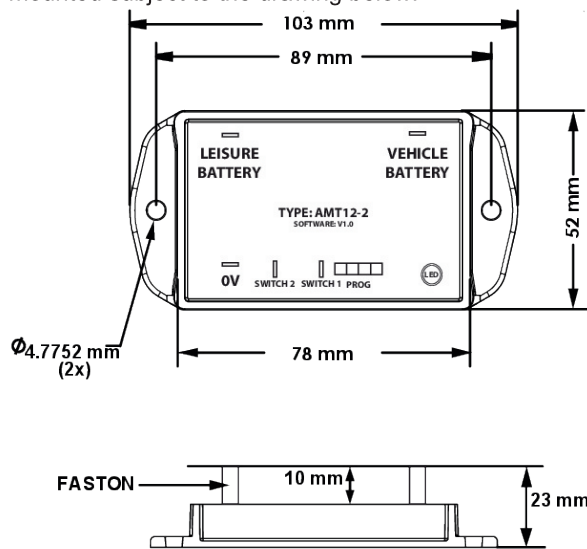

**Electrical:**

### INSTALLATION WIRING GUIDE:

ENSURE MAIN VEHICLE INPUT SUPPLY & BATTERY OUTPUT CABLES CONNECT TO THE B2B CHARGER **NOT** AMT12-2 UNIT.  
\* MINIMUM CABLE SIZE: 1.5MM SQ \* BETWEEN AMT12-2 & B2B CHARGER / MPPT SOLAR CHARGER.

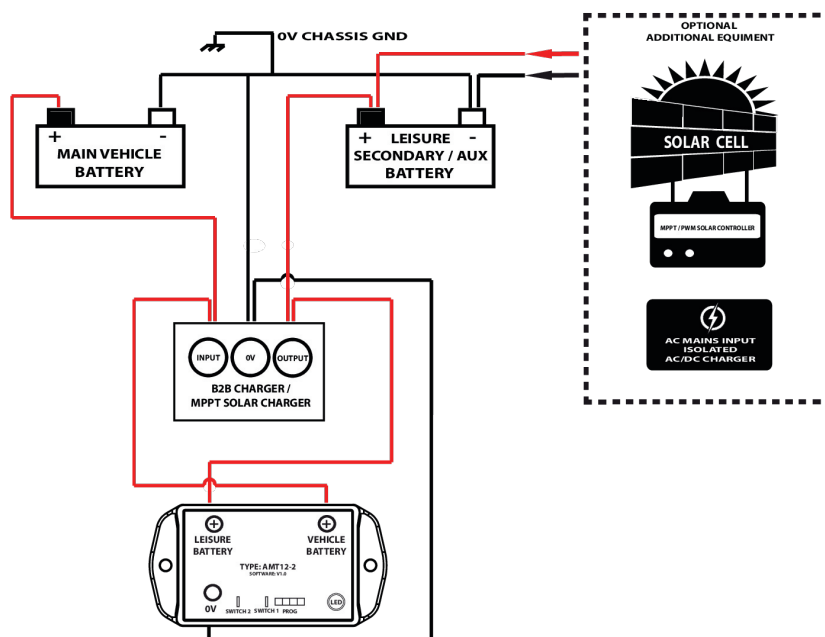

## Connection Procedure / Power up Sequence:

### To ensure normal operation:

The +ve input & -ve input from the Leisure Battery & the Vehicle Battery must be connected before any input is applied to the terminal switch SW1 input. **If this is not done the unit flashes GREEN for 1 minute.**

**Terminal switch SW1 for settings program & disable function.**

**Terminal switch SW2 for override ON function. (ONLY)**

**Programming:** To enter programming mode :

- Disconnect all power supplies.
- Connect terminal switch SW1 to +ve of Leisure Battery & Connect 0V.
- Connect Leisure Battery +12 Volts to apply power - The led will flash a number of times to indicate the current setting number.
- Remove & Replace within 40s the connection to terminal switch SW1. The led will sequence through the various settings when led indicates the settings number you require remove the +12 Volts connection from the terminal switch SW1.
- Check that the led is flashing the correct setting, If NOT OK disconnect the 12 Volts power off terminal switch SW1 & start again from step (a).

**Operations:** The Trickle Charger / Battery Maintainer programmed modes are :

	Charger Type	Leisure Battery Threshold	Vehicle Battery Threshold	Battery Type
<b>Setting 1 / 5</b>	Standard Alternator / Ignition	Leisure Battery >13.0V	Vehicle Battery >12.8V	All types of Lead Battery
<b>Setting 2 / 6</b>	Standard Alternator / Ignition	Leisure Battery >13.5V	Vehicle Battery >12.8V	Lithium Battery
<b>Setting 3 / 7</b>	Smart Alternator	Leisure Battery >13.5V	Vehicle Battery >12.4V	Lithium Battery
<b>Setting 4 / 8</b>	Smart Alternator	Leisure Battery >13.0V	Vehicle Battery >12.4V	All types of Lead Battery

Setting 5-8 are high power versions of settings and are used to cater for high parasitic drain applications while settings 1- 4 are suitable for most applications. Setting 4 is the factory default setting.

All setting switch off when Vehicle Battery is below 11.5V. The charge cycle is 6 or 10s on 15s off, When the voltage on the Auxiliary / Leisure Battery exceeds the switch on voltage & the Vehicle Battery is between 11.5V & the Vehicle Battery threshold the Trickle Charger will feed upto 3A into the Vehicle Battery in 3s bursts, The led will illuminate GREEN when this current is flowing.

When the voltage on the Auxiliary/Leisure Battery exceeds the Leisure Battery threshold & the Vehicle Battery Voltage is above the Vehicle Battery, Threshold the led will flash AMBER once every 10s to indicate the charging circuit is enabled & the Vehicle Battery is charged. If the Leisure Battery is above the Leisure Battery threshold & the Vehicle Battery is below 11.5V, AMT12-2 will flash RED.

If an Ignition signal is applied to terminal switch SW1 the Trickle Charger will be disabled & this allows the Trickle Charger to maintain a Stop/Start Vehicle Battery at a higher voltage of 12.8V.

If a signal is applied to terminal switch SW2 the Trickle Charger is turned on for 9s & off 1s. This is to allow a user to control the AMT12-2 energising with external equipment or through a switch. This could discharge the Leisure Battery or Vehicle Battery. The led will be AMBER, This is useful as a means of manually charging the Vehicle Battery.

## Trouble Shooting:

- Check Voltage at Vehicle & Leisure Battery input pin +ve's are sufficient to trigger according to the mode selected & polarity is correct.
  - Is Leisure Battery greater than Leisure Battery Threshold ? This should cause AMBER led to flash for 1s every 10s.
  - Is Vehicle Battery less than 11.5V & Leisure Battery greater than Leisure Battery Threshold ? Led will flash RED 1s every 10s.
  - Is Vehicle Battery between 11.5V & the Vehicle Battery Threshold & Leisure Battery greater than the Leisure Battery Threshold ?, The led will flash GREEN for 3s every 15s.
- Check fuses OK.
- Check Led flashes correct program mode as power is applied between Leisure Battery Input & Ground with terminal switch SW1 connected

## Optional Extras available with all units :

The Ablemail Software Interface, the windows PC & the Serial Communication Cable MEU100086 allows many of the settings to be changed to meet a specific customer requirement. The Serial Interface can also be used to drive the Ablemail Display ABD-07 OLED Display. An SVSR 12 can be used to allow the Starter & Leisure Batteries to be pooled for running loads & assisted starting of the Vehicle.



If you require any assistance or advice on this product & or its safe integration with other electrical equipment, Please contact Ablemail Technical on +44(0)161 745 7697.

Installation Instructions SWI049