

VOTRONIC

Tank Electrode 12-24 K

Tank Height 12 - 24 cm, 12 V and 24 V

Order-No. 5543

Tank Electrode 15-50 K

Tank Height 15 - 50 cm, 12 V and 24 V

Order-No. 5545

According to Drinking Water Ordinance DIN 2001-2

The tank transmitter had been designed for precise level measuring of fresh water tanks, sewage water tanks and feces tanks of plastic and metal material in campers, caravans and boats.

Measurement of the level is effected fully-automatically without mechanically moving parts according to the capacitive method of measurement, and it is transferred to the display unit via a three-core cable.

The electronic system is completely sealed. Thus, it is extremely robust and insensitive to soiling.

Tank measuring sensor, suitable and required for VOTRONIC tank displays, 1 piece per tank:

Tank Display Units:

- Fresh Water Tank Display S
- Sewage Water Tank Display S
- Feces Tank Display S
- Info Panel Pro
- Votronic VBS 2 Bus System
- Votronic VPC System
- Previous Votronic tank displays since 1987

Order No. 12 V

- 5311
- 5313
- 5315
- 5330
- All Types
- All Types
- All Types

Order No. 24 V

- 5311
- 5313
- 5315
- 6330
- All Types
- All Types
- All Types

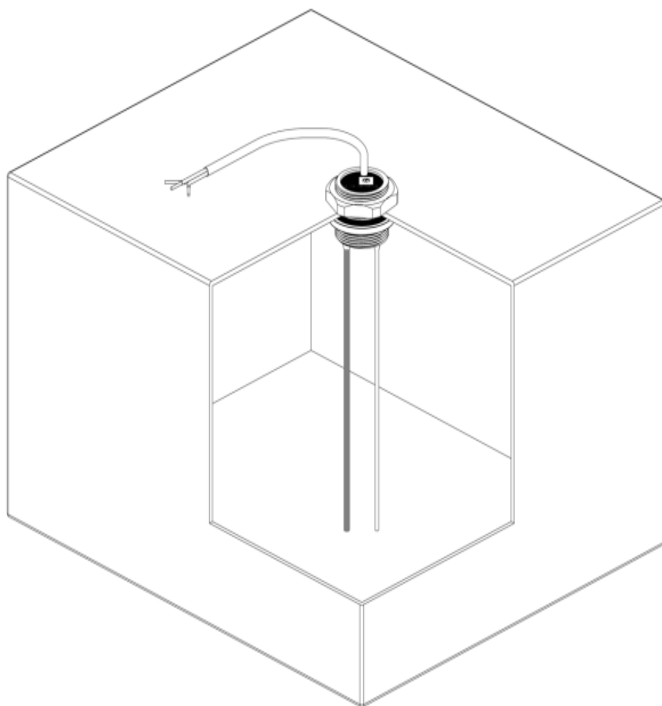

For remote level measurement, the **tank electrode** is installed directly at the tank. It is suitable for:

- Fresh water (if applicable, please observe the Guidelines for Drinking-Water Quality DIN 2001-2)
- Sewage water, grey water
- Feces sewage water

- Plastic tanks, any material
- Metal tanks (aluminium, steel, stainless steel, etc.)

- Adjustable to tank heights:
12 to 24 cm or 15 cm to 50 cm.

Functioning:

The level in the tank is measured capacitively. The insulated stick (probe) and the surrounding water form a kind of "capacitor", the size of which is growing with the level, and which is measured by the electronic system. The contact to the water as "antipole" is effected by a stainless steel stick.

Brief Instruction:

1. Produce a mounting hole at the tank with a diameter of 38 mm or thread PG29
2. Determine the kind of installation, inside or outside the tank, and measure the tank height
3. Cut both measuring sticks to the desired length (observe a clearance of 10 - 20 mm between sticks and tank bottom)
4. Reinsert the insulating cap on the insulated stick (observe the tightness)
5. Install the tank transmitter inside or outside using the delivered packing washers
6. Set the measured water depth at the scale
7. Produce the electrical connection to the display unit
8. Ready for start-up

Preliminary Installation:

The tank electrode is designed for vertical installation from the tank top. In contrast to sewage water and feces tanks (deposit), an installation at the lower side of the tank is also possible. The tank electrode should be placed at the topmost location and in the tank centre.

Mounting hole, diameter 38 mm, or thread PG29.

Depending on the local conditions (available space above the tank, cutout of the intermediate floor, tank height etc.), the tank transmitter can be installed at the tank inside or outside (for the short type tank electrode 12-24 K is for best results, if possible, the installation outside recommended):

Installation inside

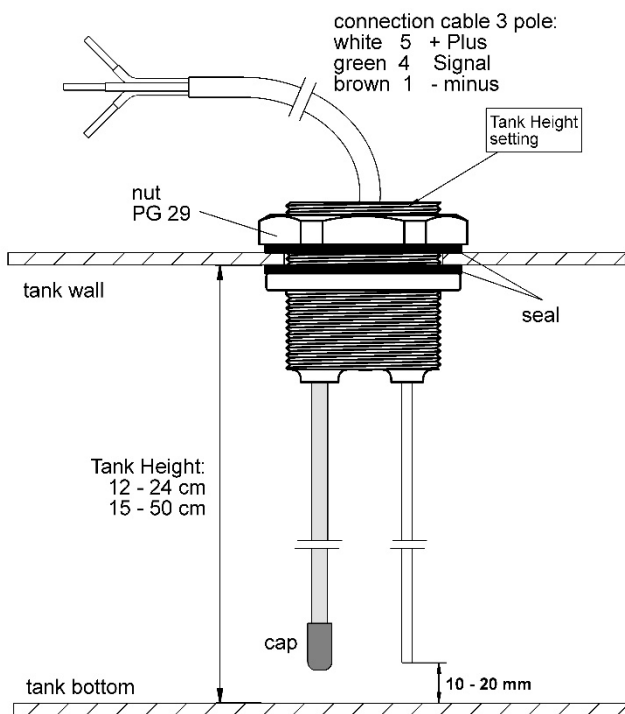

Installation outside

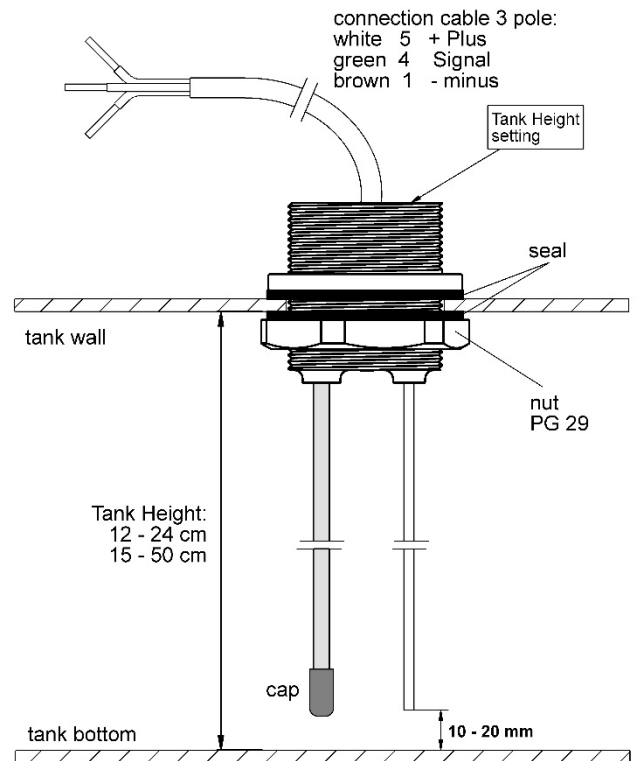

After that, the two stick probes must be cut to identical length (metal saw, strong side cutter, bolt cutter).

It is important, that a clearance of at least 10 - 20 mm is left between tank bottom and probe ends (deposit, up-and-down movement of the tank bottom and of the tank top during driving etc.)

Burr the sticks, and reinsert the insulating cap on the stick probe being insulated by the plastic pipe.

A thorough sealing between the insulating cap and the plastic pipe is decisive for proper operation of the tank electrode!

Set the adjuster tank height "FULL" 100 %:

Example: The scale indicates the value 18 cm as adjusted Tank Height

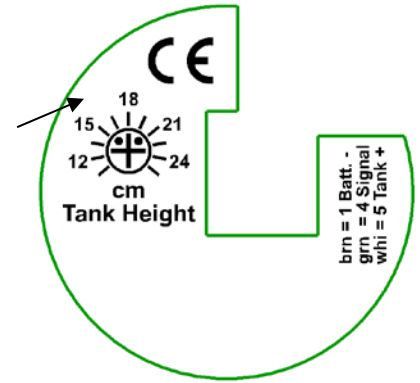

Configuration of Connections:

<u>Colour</u>	<u>Connection No. Tank Display</u>	<u>Function</u>	<u>recommended Cable Cross-Section</u>
white	5 = Tank + (Plus)	+ Operating Voltage, from Display Unit Connection 5	0.5 - 1 mm ²
green	4 = Tank Signal	Measuring Signal to Display Unit Connection 4 , 0...2.2 V	0.5 - 1 mm ²
brown	1 = Battery -	- Operating Voltage (common, minus) or Body Ground, 1	0.5 - 1 mm ²

The tank electrode K is protected against any kind of reverse battery. It is recommendable to use connection cables of different colours to avoid malfunctions due to mixed up connections.

As soon as the display unit has been installed according to the operating manual, the battery can be connected.

Start-up and Adjustment:

The adjuster at the upper side of the tank electrode is used to adjust the tank height to 100 % "FULL" at the display:

Insert a folding rule into the mounting hole of the tank to measure the exact tank depth (inside width), and set the adjuster for the "water depth" to this value. The adjustment procedure is completed.

The functions of the display can now be simulated with several water levels in the tank (or in a bucket being filled with water) or by withdrawing the tank electrode out of the full tank (or bucket).

Fine adjustment of the set water depth can be corrected or changed at any time with full tank.

Final Installation:

The delivered packing washers are placed between tank, casing flange and coupling ring PG 29. Screw the tank transmitter in place using the coupling ring PG 29.

In case of underfloor installation of the tank, the adjuster must be protected with a permanently elastic sealant against aggressive environmental influences (de-icing salt etc.).

Tips and Tricks:

No reaction of display:

- a. Cable **4** = *Tank Signal* Withdraw connector by way of trial and direct it to connection "5":
The display should increase to 100 % ! **Otherwise:**
- b. Battery connection or fuse defective → check!
- c. Cable **5** = *Tank Plus* interrupted → check!
- d. Cable **4** = *Tank Signal*: Short-circuit to ground → check!

Constant display of 100 % on the display unit:

- a. Cable **4** = *Tank Signal* Withdraw it and direct it to ground: Display must be empty!
- b. Cable **1** = *Battery Minus / Ground* is interrupted or does not have any contact due to paint residues at the body → check!
- c. The insulated stick probe is contacting water: The silicone cap is leaky or dropped-off, the plastic pipe is damaged
→ check!

Indication Errors:

- a. Intense soiling and furring of the insulated stick probe by stuck solids in the sewage water tank and feces tank
→ Rinse tank (no seawater), clean it if required !



Safety Regulations and Appropriate Application:

The tank measuring sensor has been designed according to the valid safety regulations.

Application is only allowed, if the unit is in technically faultless condition, with protected board battery voltage of the indicated value and only for measurement of water or hydrous media.

- **Never use the unit at locations where the risk of gas or dust explosion exists!**
- The unit is to be disconnected from any connection prior to execution of electrically welding or work on the electric system.
- Cables are always to be laid in such a way that damage is excluded. Observe to fasten them tightly.
- Never lay 12 V (24 V) cables and 230 V mains supply cables into the same cable conduit (empty conduit).
- Check live cables or leads periodically for insulation faults, points of break or loosened connections. Occurring defects must be remedied immediately.
- If the user is not able to draw from the manual, which characteristic values are valid for a unit or which regulations are to be observed, a specialist is to be consulted.
- The user/buyer is obliged to observe any construction and safety regulations.
- The unit is not equipped with parts, which can be replaced by the user.
- The warranty period is 36 months from the purchase date (against presentation of the sales slip or invoice).
- The warranty will be void in case of any inappropriate utilisation of the unit, if it is used beyond the technical specification, in case of improper operation or external intervention. We do not assume any liability for any damage resulting hereof. The liability exclusion is extended to any service being executed by third, which has not been ordered by us in writing. Service is to be effected exclusively by VOTRONIC
D-36341 Lauterbach.

Notes:

Notes:



Declaration of Conformity:

In accordance with the provisions of the statutory requirements and the relevant directives, Electrical Equipment (Safety) Regulations 2016, Electromagnetic Compatibility Regulations 2016, The Restriction of the Use of Certain Hazardous Substances in Electrical and Electronic Equipment Regulations 2012 this product complies with the following standards or normative documents:
BS EN55014-1; BS EN61000-6-1; BS EN61000-4-2; BS EN61000-4-3; BS EN61000-4-4; BS EN62368-1; BS EN50498, BS EN IEC 63000.



Declaration of Conformity:

In accordance with the provisions of Directives 2014/35/EU, 2014/30/EU, 2009/19/EC, this product complies with the following standards or normative documents:
EN55014-1; EN61000-6-1; EN61000-4-2; EN61000-4-3; EN61000-4-4; EN62368-1; EN50498.



The product must not be disposed of in the household waste.



The product is RoHS compliant. It complies with the directive 2015/863/EU for Reduction of Hazardous Substances in electrical and electronic equipment.



Recycling:

At the end of its useful life, you can send us this device for professional disposal:
You can find more information about this on our website at www.votronic.de/recycling

Technical Data:

Operating Voltage:	12 V-/24 V-DC Battery voltage (of the display)
Operating Voltage Range:	7...32 V
Current Consumption:	4...7 mA
Signal Output 0...100 %:	0...2.2 V,
Measuring Method:	capacitive, suitable for short-time and continuous operation
Tank Height, adjustable:	12...24 cm, 15...50 cm
Mounting Hole:	38 mm or thread PG 29
Flange Diameter:	46.5 mm
Length Connection Cable:	75 cm

Delivery Scope:

- 1 Tank Electrode 12-24 K or 15-50 K
- 1 Coupling Ring PG 29
- 2 Packing Washer
- 1 Installation and Operating Manual

Subject to misprints, errors and technical modification without notice.

All rights reserved. This material may not be published, broadcast, rewritten or redistributed in whole or part without the express written consent of the manufacturer. Copyright © VOTRONIC 06/2023

Made in Germany by VOTRONIC Elektronik-Systeme GmbH, Johann-Friedrich-Diehm-Str. 2, 36341 Lauterbach/GERMANY
Phone: +49 (0)6641/91173-0 Fax: +49 (0)6641/91173-10 E-mail: info@votronic.de Internet: www.votronic.de